

# San Ace 120L 9LG type

## High Airflow Long Life Fan

### Features

#### Long Life

The San Ace 120L 9LG type has an expected life of 180,000 hours (approximately 20 years), 1.8 times that of our conventional long life fan,\* making this fan ideal for equipment that must operate without maintenance for extended periods.

#### High Airflow and High Static Pressure

The maximum airflow of the San Ace 120L 9LG type is approximately 1.8 times and the maximum static pressure is approximately 3 times higher than that of our conventional long life fan.\*

\*: Specification of Model No. 9LG1224P1G001. Our conventional long life fan is 120 x 120 x 38 mm "San Ace 120L", Model No. 9LB1224S101.



## 120×120×38mm

### Specifications

The following nos. have **PWM controls, pulse sensors.**

Model No.	Rated Voltage [V]	Operating Voltage Range [V]	PWM Duty Cycle (Note1) [%]	Rated Current [A]	Rated Input [W]	Rated Speed [min <sup>-1</sup> ]	Max. Airflow [m <sup>3</sup> /min] [CFM]	Max. Static Pressure [Pa] [inchH <sub>2</sub> O]	SPL [dB(A)]	Operating Temperature [°C]	Expected Life [h]
9LG1212P1G001	12	8.0 to 13.8	100	3.2	38.4	6,550	7.00 247.1	370 1.48	62	-20 to +70	180,000 / 60 °C
			20	0.24	2.88	2,000	2.13 75.2	34.4 0.13	36		
9LG1212P1S001			100	2.2	26.4	5,600	6.00 211.8	270 1.08	58		
			20	0.24	2.88	2,000	2.13 75.2	34.4 0.13	36		
9LG1212P1H001			100	1.4	16.8	4,700	5.00 176.5	190 0.76	54		
			20	0.24	2.88	2,000	2.13 75.2	34.4 0.13	36		
9LG1224P1G001	24	15 to 30	100	1.6	38.4	6,550	7.00 247.1	370 1.48	62		
			20	0.12	2.88	2,000	2.13 75.2	34.4 0.13	36		
9LG1224P1S001			100	1.1	26.4	5,600	6.00 211.8	270 1.08	58		
			20	0.12	2.88	2,000	2.13 75.2	34.4 0.13	36		
9LG1224P1H001			100	0.7	16.8	4,700	5.00 176.5	190 0.76	54		
			20	0.12	2.88	2,000	2.13 75.2	34.4 0.13	36		
9LG1248P1G001	48	36 to 60	100	0.8	38.4	6,550	7.00 247.1	370 1.48	62		
			20	0.08	3.84	2,000	2.13 75.2	34.4 0.13	36		
9LG1248P1S001			100	0.55	26.4	5,600	6.00 211.8	270 1.08	58		
			20	0.08	3.84	2,000	2.13 75.2	34.4 0.13	36		
9LG1248P1H001			100	0.35	16.8	4,700	5.00 176.5	190 0.76	54		
			20	0.08	3.84	2,000	2.13 75.2	34.4 0.13	36		

Note1: PWM Frequency: 25 kHz

Note2: Fans do not rotate when PWM duty cycle is 0%.

Available options: **Without Sensor** **Pulse Sensor**

Please inquire as the availability of these functions depends on the model: **Lock Sensor**

### Common Specifications

- Material ..... Frame: Aluminum, Impeller: Plastics (Flammability: UL94V-1)
- Expected Life ..... Refer to specifications  
(L10: Survival rate: 90% at 60 °C, rated voltage, and continuously run in a free air state)
- Motor Protection System ..... Current blocking function and reverse polarity protection
- Dielectric Strength ..... 50 / 60 Hz, 500 VAC, 1 minute (between lead conductor and frame)
- Sound Pressure Level (SPL) ..... Expressed as the value at 1 m from air inlet side
- Operating Temperature ..... Refer to specifications (Non-condensing)
- Storage Temperature ..... -30 °C to +70 °C (Non-condensing)
- Lead Wire ..... ⊕Red ⊖Black Sensor: Yellow Control: Brown
- Mass ..... Approx. 420 g

## Airflow - Static Pressure Characteristics

### • PWM Duty Cycle

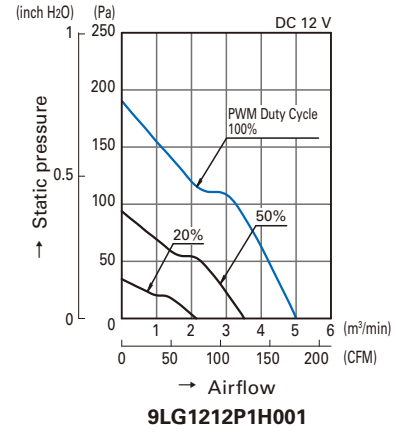
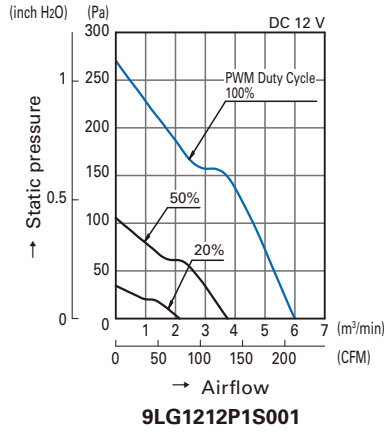
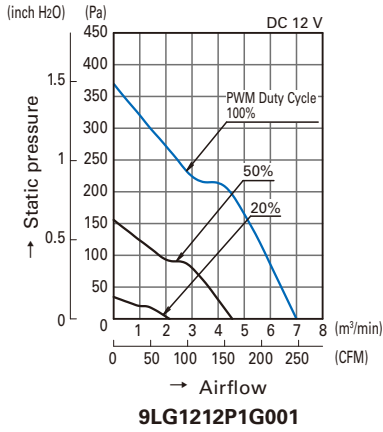

### • Operating Voltage Range

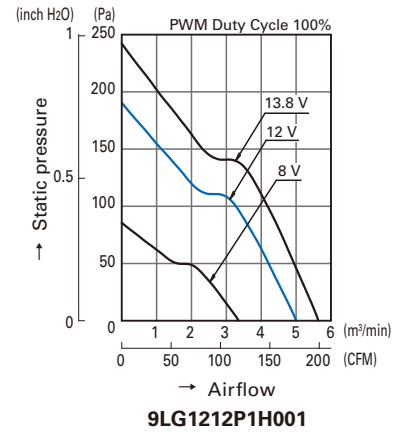
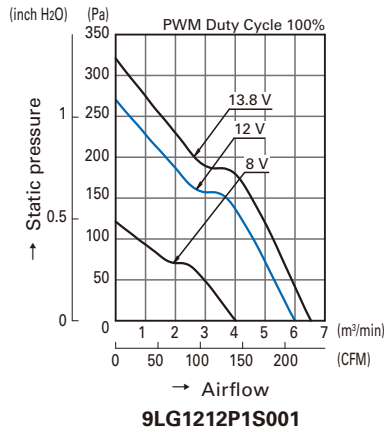
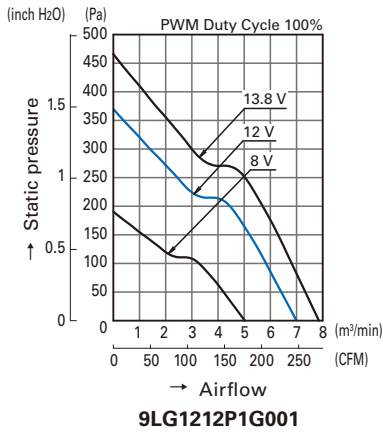

### • PWM Duty Cycle

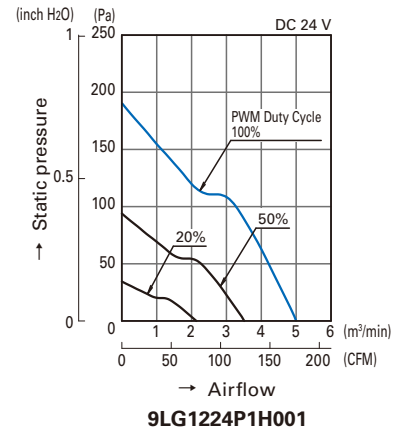
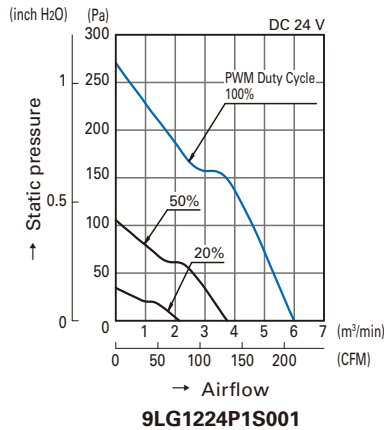
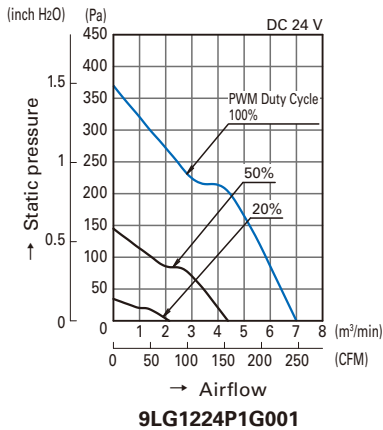

### • Operating Voltage Range

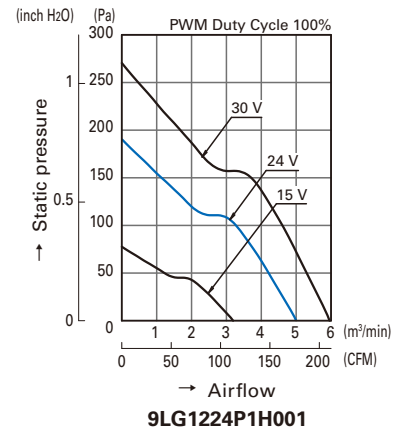
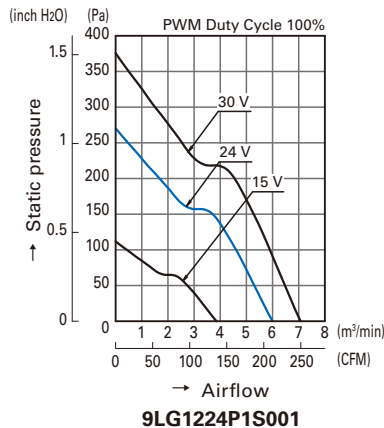
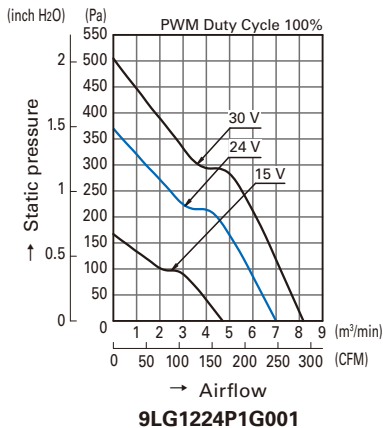

## Airflow - Static Pressure Characteristics

### PWM Duty Cycle

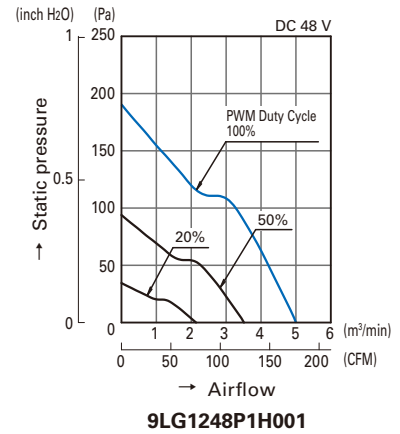
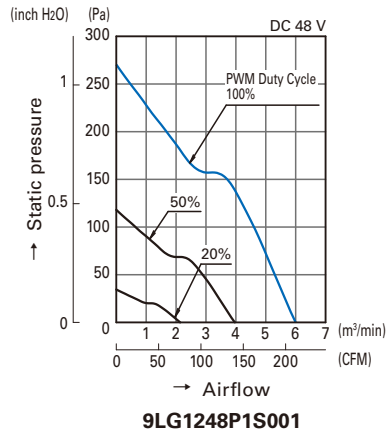
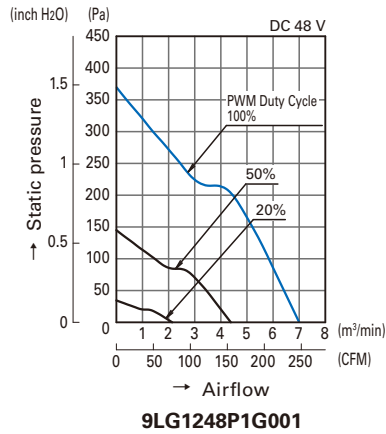

### Operating Voltage Range

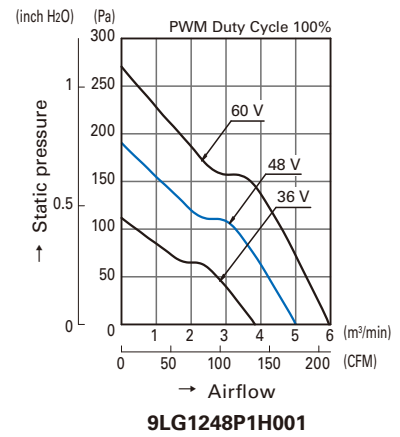
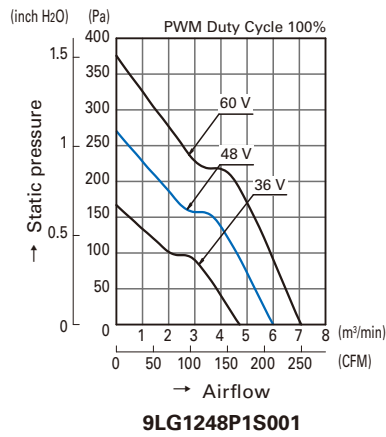
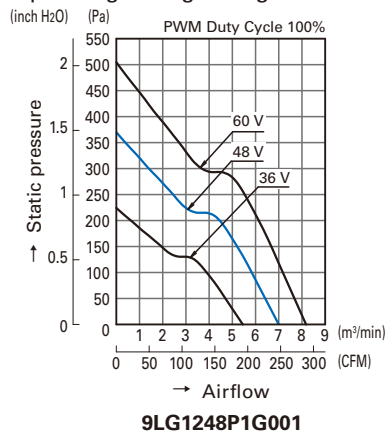

## PWM Duty - Speed Characteristics Example

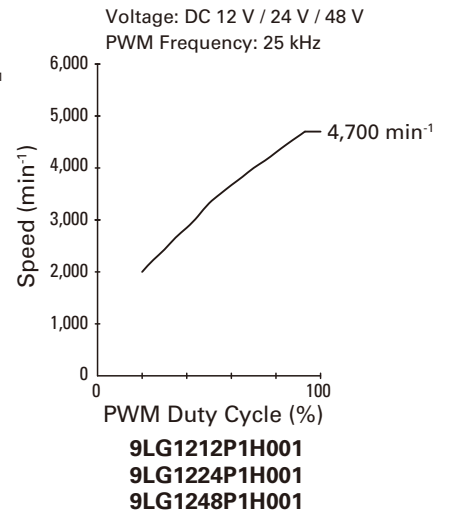
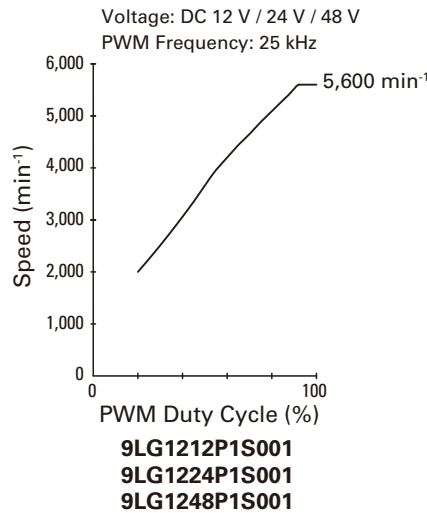
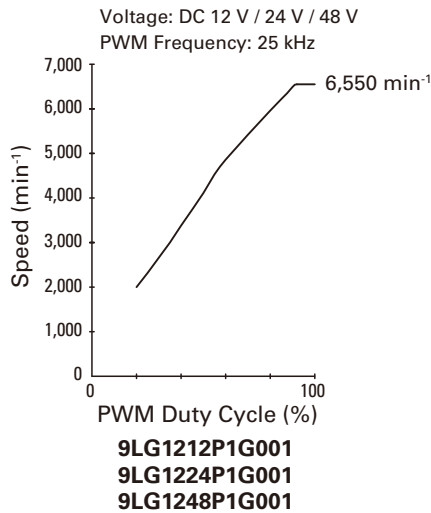

## PWM Input Signal Example

### Input Signal Waveform

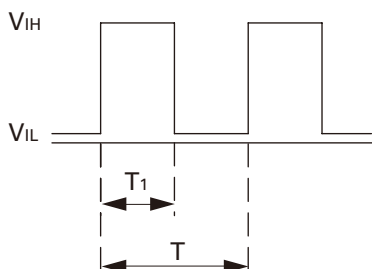

V<sub>IH</sub>=4.75 V to 5.25 V

V<sub>IL</sub>=0 V to 0.4 V

$$\text{PWM Duty Cycle (\%)} = \frac{T_1}{T} \times 100$$

$$\text{PWM Frequency 25 (kHz)} = \frac{1}{T}$$

Source Current (I<sub>source</sub>): 1 mA Max. at control voltage 0 V

Sink Current (I<sub>sink</sub>): 1 mA Max. at control voltage 5.25 V

Control Terminal Voltage: 5.25 V Max. (Open Circuit)

When the control lead wire is open, the fan speed is the same as the one at a PWM duty cycle of 100%.

Either TTL input, open collector or open drain can be used for PWM control input signal.

## Example of Connection Schematic

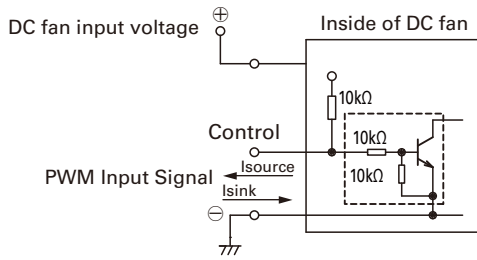

**9LG1212P1G001**  
**9LG1212P1S001**  
**9LG1212P1H001**

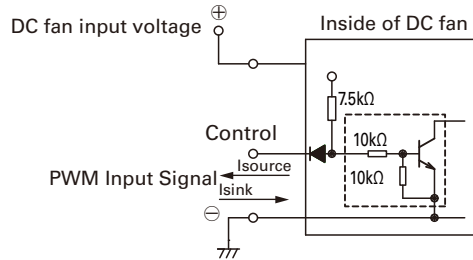

**9LG1224P1G001** **9LG1248P1G001**  
**9LG1224P1S001** **9LG1248P1S001**  
**9LG1224P1H001** **9LG1248P1H001**

## Specifications for Pulse Sensors

Output circuit: Open collector

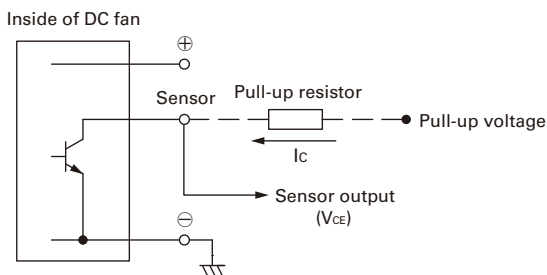

**Rated Voltage 12 V, 24 V Fan**

$V_{CE} = +30 \text{ V MAX.}$

$I_c = 10 \text{ mA MAX. [} V_{OL} = V_{CE}(\text{SAT}) = 0.6 \text{ V MAX.]}$

**Rated Voltage 48 V Fan**

$V_{CE} = +60 \text{ V MAX.}$

$I_c = 10 \text{ mA MAX. [} V_{OL} = V_{CE}(\text{SAT}) = 0.6 \text{ V MAX.]}$

Output Waveform (Need pull-up resistor)

In case of steady running

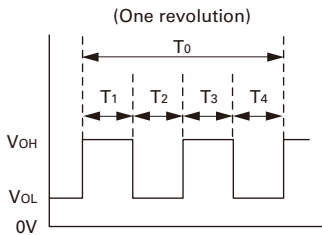

$$T_{1\sim4} \doteq (1/4) T_0$$

$$T_{1\sim4} \doteq (1/4) T_0 = 60/4N \text{ (sec)}$$

$$N = \text{Fan speed (min}^{-1}\text{)}$$

## Dimensions (unit : mm)

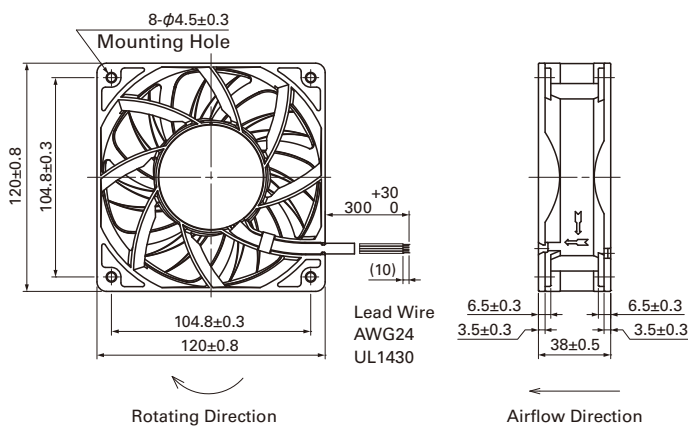

## Reference Dimensions of Mounting Holes and Vent Opening (unit : mm)

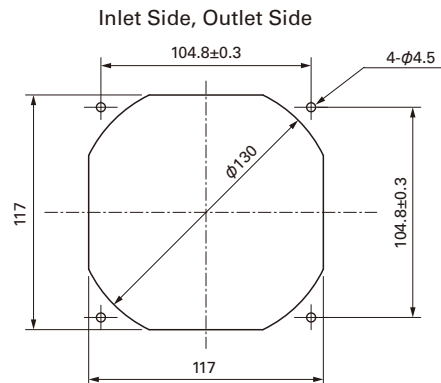

●The products shown in this catalog are subject to Japanese Export Control Law. Diversion contrary to the law of exporting country is prohibited.

**SANYO DENKI CO., LTD.** 3-33-1, Minami-Otsuka, Toshima-ku, Tokyo, 170-8451, Japan TEL: +81 3 5927 1020

<http://www.sanyodenki.com>

The names of companies and/or their products specified in this catalog are the trade names, and/or trademarks and/or registered trademarks of such respective companies. "San Ace" is a trademark of SANYO DENKI CO.,LTD.

Specifications are subject to change without notice.

CATALOG No. C1037B001 '14.9