

**φ172<sub>mm</sub>**

# San Ace 172W

51mm thick (Sidecut type 9WG type)  
 51mm thick (Sidecut type 9WE type)  
 51mm thick (Round type 9WE type)



## General Specifications

- Material ..... Frame: Aluminum,  
 Impeller: Plastics (Flammability: UL94V-1)
- Expected Life ..... Refer to specifications (Indoor,L10: Survival rate: 90% at 60°C ,  
 rated voltage, and continuously run in a free air state)
- Lead Wire ..... ⊕red ⊖black (Sensor) yellow (Control) brown
- Storage Temperature ..... -30°C to +70°C (Non-condensing)

**φ172mm × 150mm × 51mm** (Mass : 860g) **IP 68** **9WG type** **Sidecut type**

## Specifications

The following nos. **have PWM controls and pulse sensors.**

Model No.	Rated Voltage [V]	Operating Voltage Range [V]	PWM duty cycle* [%]	Rated Current [A]	Rated Input [W]	Rated Speed [min <sup>-1</sup> ]	Max. Airflow [m <sup>3</sup> /min] [CFM]	Max. Static Pressure [Pa] [inchH <sub>2</sub> O]	SPL [dB(A)]	Operating Temperature [°C]	Expected Life <sup>nom</sup> [h]
9WG5748P5G001	48	40.8 to 55.2	100	2.91	140.0	8,600	15.46 546	1000 4.02	78	-20 to +70	40,000/60°C (70,000/40°C)
			0	0.21	10.1	2,000	3.59 127	75.1 0.30	40		
9WG5748P5H001			100	1.62	78.0	6,500	11.60 410	770 3.09	71		
			0	0.21	10.1	2,000	3.59 127	75.1 0.30	40		

Note: Expected life at 40°C ambient is just reference value.

※PWM Frequency : 25kHz

Some models can also be equipped with pulse sensors (no PWM control functions) as an option. Please refer to the index (pp. 417 to 437).

## Dimensions (unit : mm)

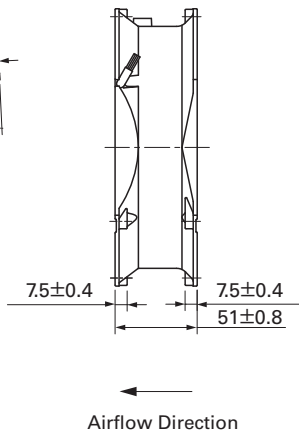
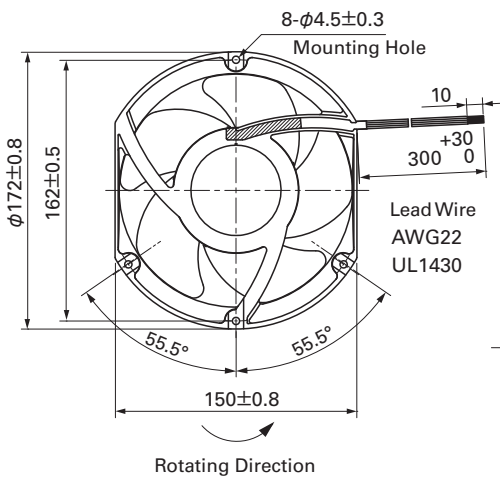

## Reference Dimension of Mounting Holes and Vent Opening (unit : mm)

Inlet side, Outlet side

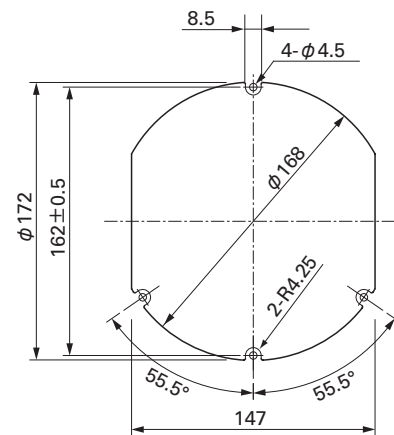

## Options (unit : mm)

### Finger Guards

Model : 109-319J Color Surface treatment : Nickel-chrome plating (silver)

For the finger guard Model: 109-319J, fix the finger guard to four holes as shown in the diagram.

Inlet side, Outlet side

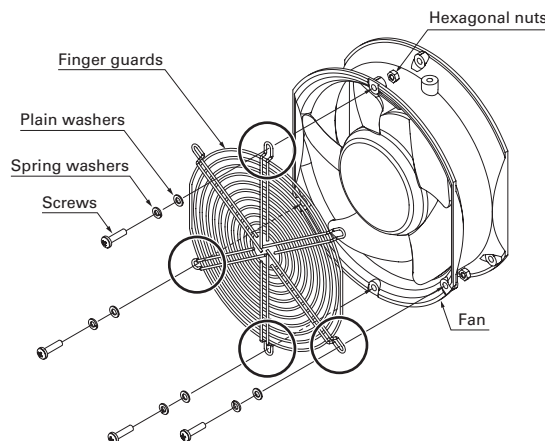
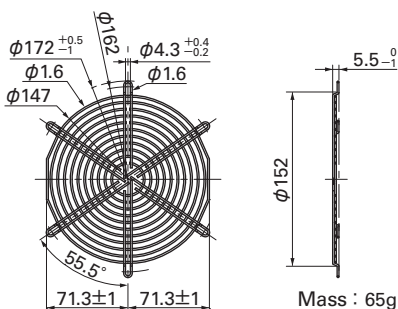

## Options (unit : mm)

### Finger Guards

Model : 109-319E Surface treatment : Nickel-chrome plating (silver) Color : 109-319H : Cation electropainting (black)

Model : 109-320 Surface treatment : Nickel-chrome plating Color (silver)

For the finger guard Model: 109-319E, 109-319H, 109-320, fix the finger guard to two holes as shown in the diagram. Do not fix it to any other holes.

Inlet side, Outlet side

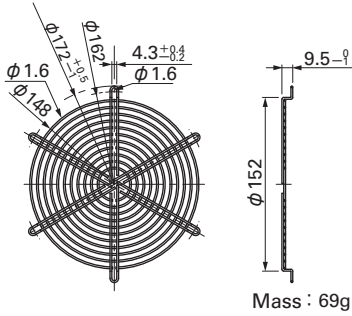

Outlet side

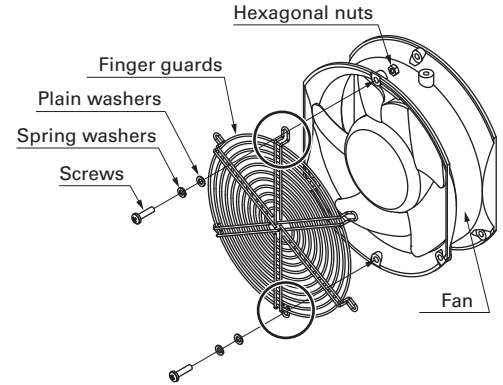
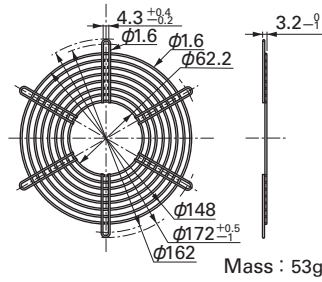

## Airflow - Static Pressure Characteristics

### PWM Duty Cycle

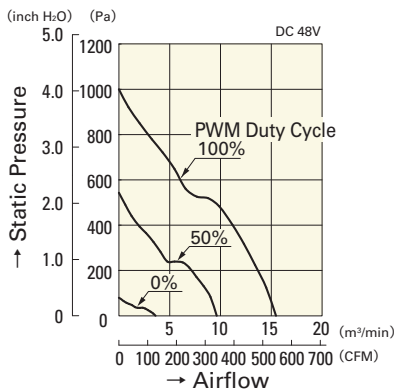

9WG5748P5G001

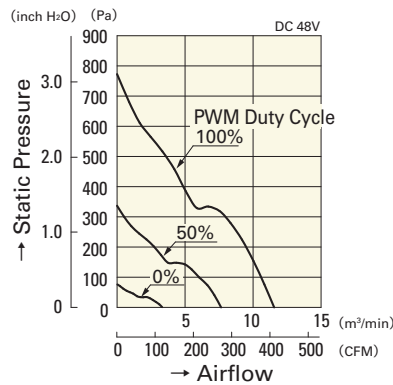

9WG5748P5H001

### Operating Voltage Range

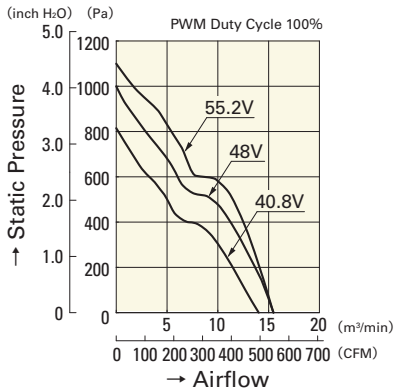

9WG5748P5G001

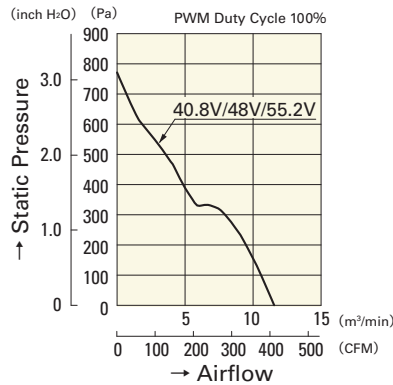

9WG5748P5H001

## PWM Duty - Speed Characteristics Example

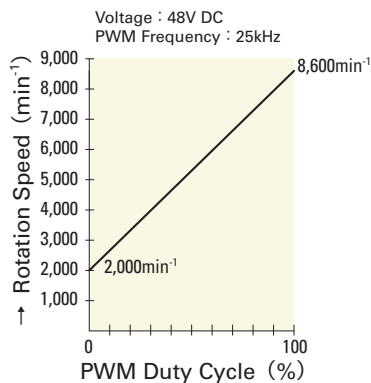

9WG5748P5G001

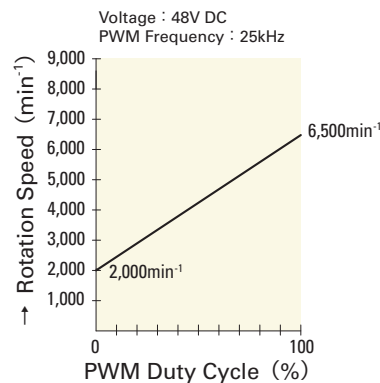

9WG5748P5H001